

TWO BURNER DAMAK STOVE

Sustainable Harvest International

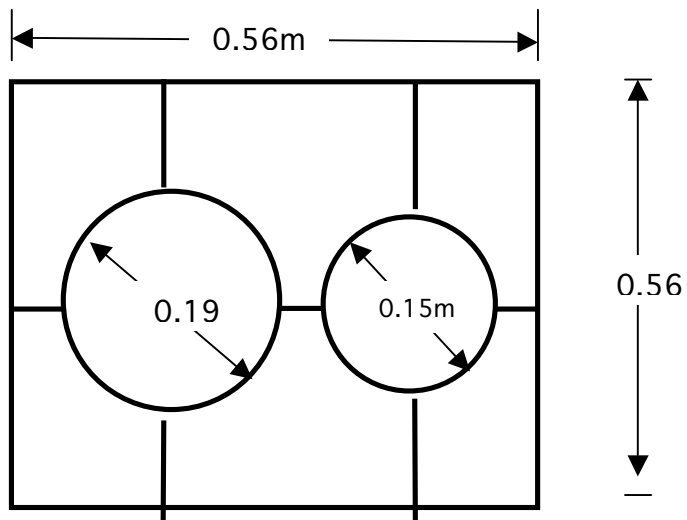

GRILLS

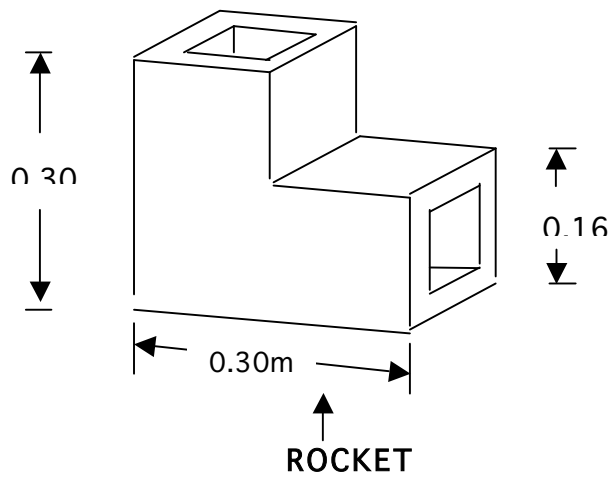
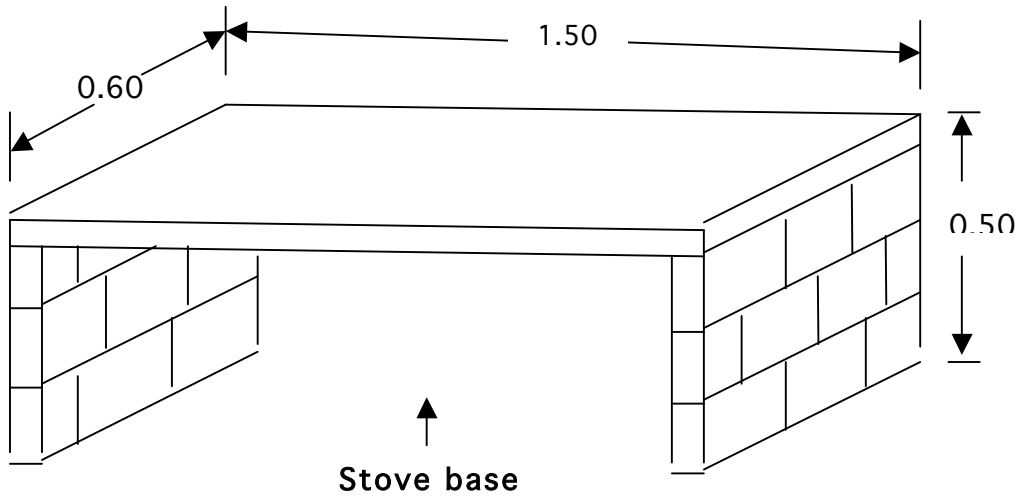
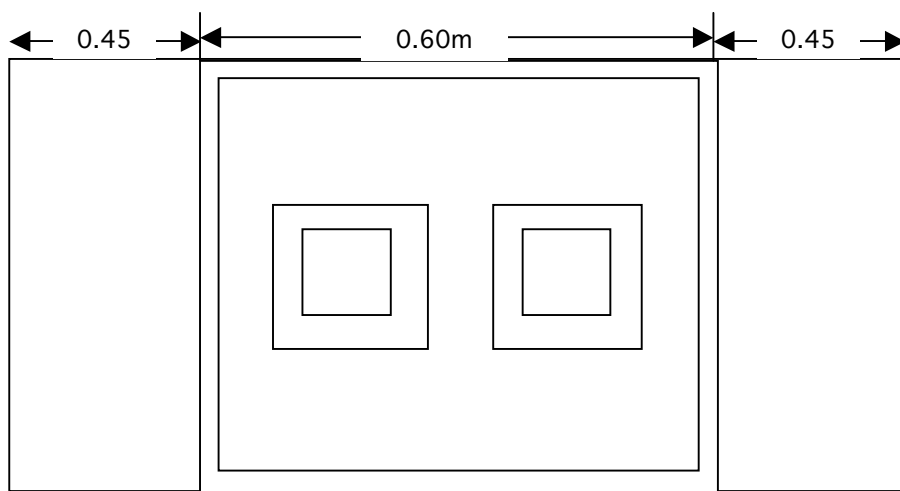
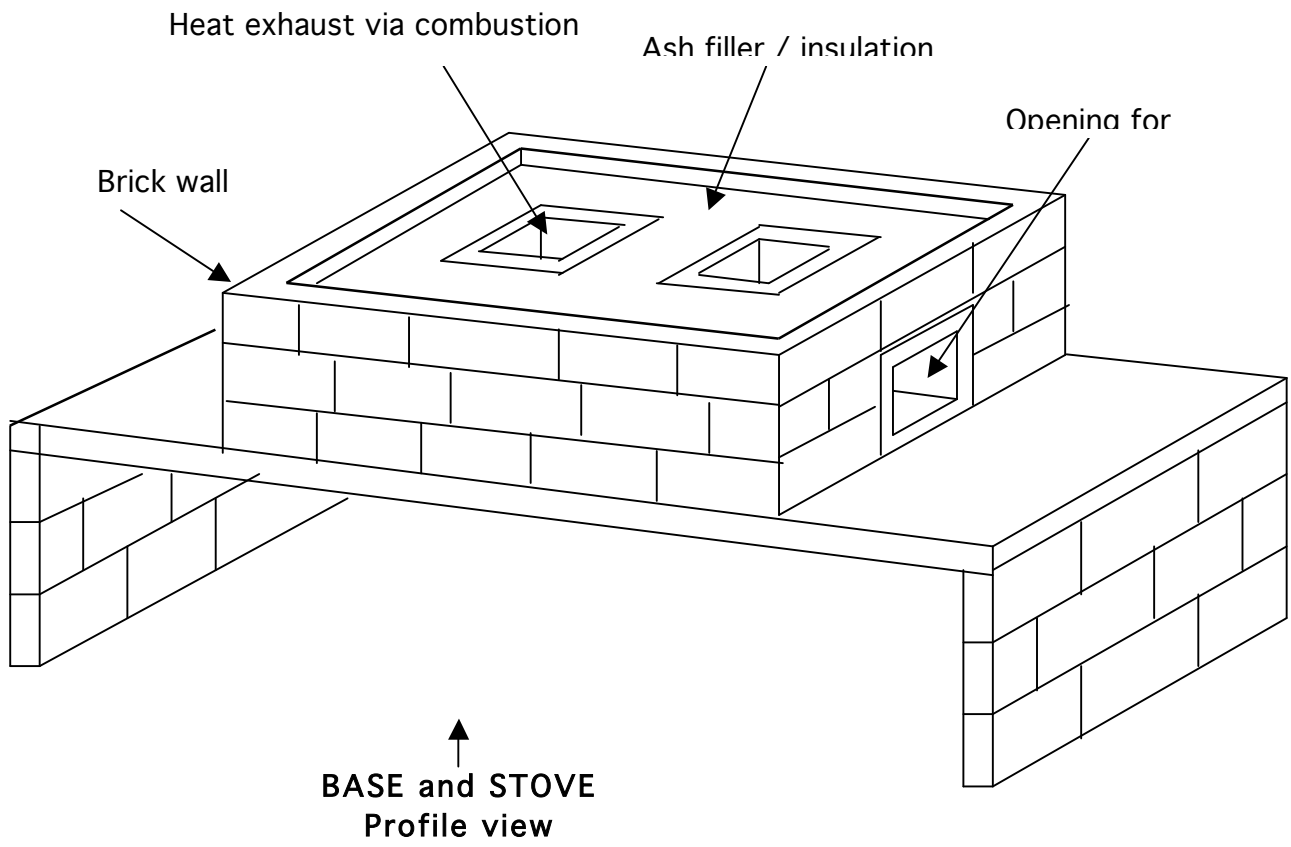

Overhead view

COSTS FOR TWO BURNER DAMAK STOVE
(costs based on Panama market prices)

Quantity	Description	Price / unit	Family contribution	SHI contribution	Subtotal
10	Clay tiles of 30 x 30 x 4.5 cm	0.50		5.00	5.00
22	Bricks of 25 x 14 x 8 cm	0.30		6.60	6.60
6	Cinderblocks 4"	0.50		3.00	3.00
1.5	Steel bar (rebar) 1/2	9.00		13.50	13.50
1.5	Bags of cement	9.00		13.50	13.50
0.5	Pounds of 2" nails	1.20		0.60	0.60
0.5	Pounds of plain wire	1.00		0.50	0.50
1	Metal grill for 2 burners (locally made)	20.00		20.00	20.00
5	Buckets of sand	1.50	7.50		7.50
6	Buckets of gravel	1.50	9.00		9.00
4	Buckets of ash	2.00	8.00		8.00
4	Wood planks 1"x12"x6'	3.00	12.00		12.00
2	Wood planks 1"x12"x6'	4.00	8.00		8.00
1	Labor for bricklayer	20.00		20.00	20.00
Totals			44.50	82.70	127.20